

Matiere: S235

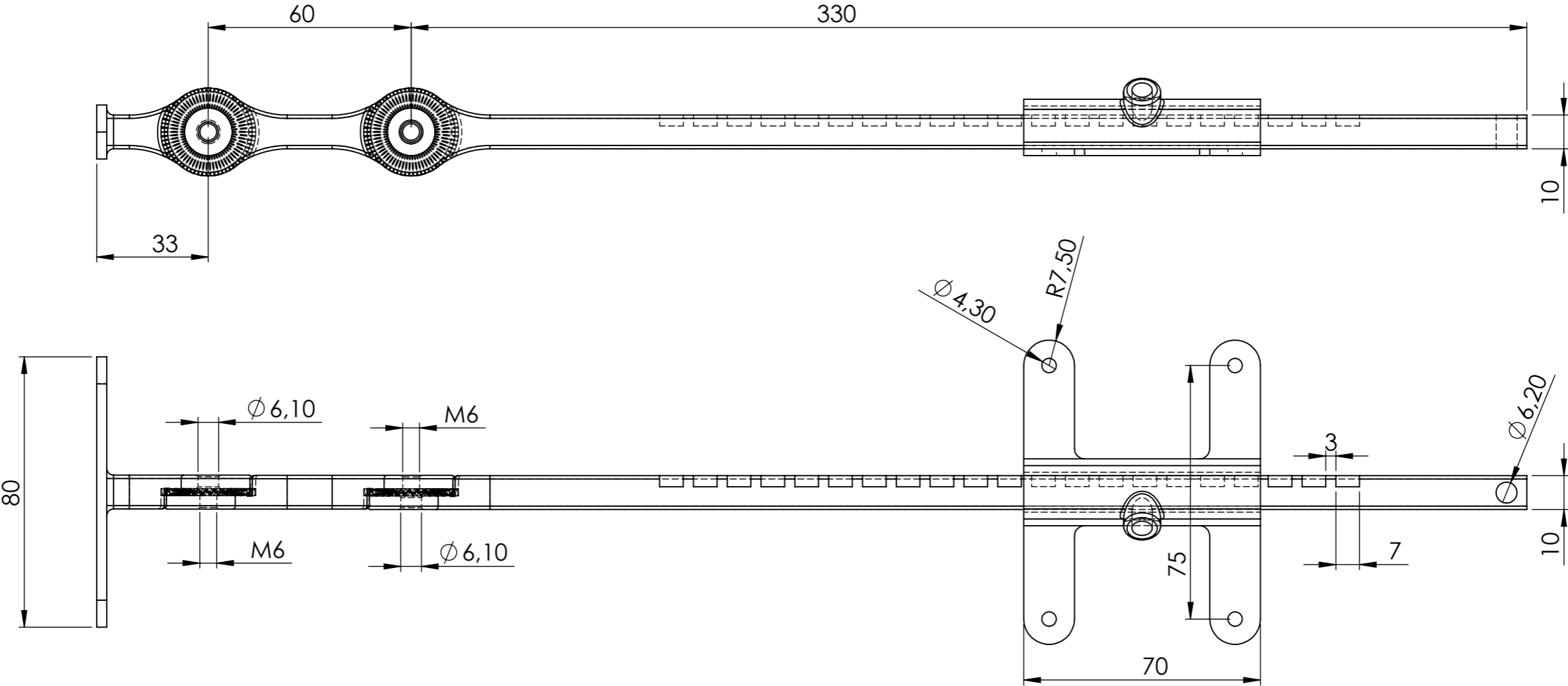
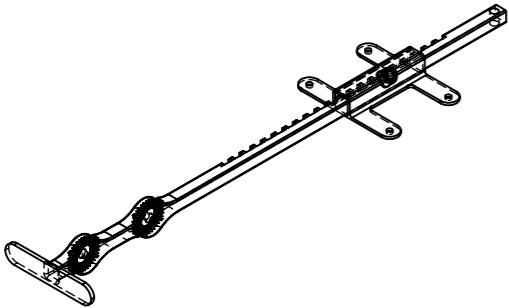

| | | | | | | | | | | | |
|--|--|-----|--|-----------|--|---|--|--|--|-----------------|--|
| SAUF INDICATION CONTRAIRE: LES COTES SONT EN MILLIMETRES ETAT DE SURFACE: RA1.6 TOLERANCES: +/-0.1mm LINEAIRES: +/-0.1mm ANGULAIRES: +/- 0.5° | | | | FINITION: | | CASSER LES ANGLES VIFS/ BREAK SHARP EDGE | | NE PAS CHANGER L'ECHELLE | | REVISION | |
| | | | | | | | | SAUF INDICATION CONTRAIRE: LES COTES SONT EN MILLIMETRES/ EXCEPT INDICATION ALL THE DIMENSIONS ARE IN MILLIMETRES | | | |
| | | NOM | | SIGNATURE | | DATE | | Noixcrantee.com | | | |
| AUTEUR | | | | | | | | | | | |
| VERIF. | | | | | | | | | | | |
| APPR. | | | | | | | | | | | |
| FAB. | | | | | | | | | | | |
| QUAL. | | | | | | | | MATERIAU: | | No. DE PLAN | |
| | | | | | | | | | | NC11 | |
| | | | | | | | | MASSE: | | A3 | |
| | | | | | | | | ECHELLE:1:1.5 | | FEUILLE 1 SUR 1 | |